

## **WB61 Datasheet**

Amp'ed RF Technology, Inc.

## WB61 Product Specification PRELIMINARY



26.9 mm x 15.2 mm x 2.8 mm

### Description

Amp'ed RF Tech presents our WB61 Wi-Fi & Bluetooth combo module: 802.11abgn/Bluetooth v4.0. The WB61 is a small footprint low cost RF module intended to help customers shorten product development cycles and reduce cost. It is fully compatible with Linux & Android systems, or our own upper layer stack, Amp'ed UP, for a complete host & controller solution.

### Features

#### WLAN

- 802.11a/b/g/n, 802.11d, 802.11r
- Output Power, +21.5dBm
- Interface, SDIO 2.0, SPI
- Wi-Fi Direct (concurrent)
- Wi-Fi Display
- Wi-Fi Protected Setup
- Soft Access Point
- Hotspot 2.0
- Security: WPAI/WPA2, AES, WEP

#### Bluetooth

- Bluetooth v4.0 + BLE
- Protocol Stack, up to HCI
- Output Power, +13dBm
- Interface, H4 (UART), PCM Audio
- Wi-Fi coexistence for BT Classic and BLE

#### Hardware

- Serial interfaces: UART, PCM, SDIO
- Deep sleep current, 20  $\mu$ A
- RoHS conformance

## Contents

<b>1. Hardware Specifications</b> .....	<b>4</b>
1.1. Recommended Operating Conditions .....	4
1.2. Absolute Maximum Ratings .....	4
<b>1.3. Current Consumption</b> .....	<b>4</b>
1.4. Selected RF Characteristics.....	6
1.5. Pin Assignment WB61S .....	8
1.6. Layout Drawing WB61S .....	9
<b>2. Hardware Design</b> .....	<b>9</b>
2.1. Module Reflow Installation .....	10
<b>3. Reference Design Example WB61</b> .....	<b>11</b>
<b>4. Startup behavior</b> .....	<b>12</b>
4.1. RESET .....	12
4.2. UART .....	12
4.3. SDIO and SPI interface.....	12
<b>5. RF Path Control</b> .....	<b>12</b>
5.1 WB61S Control.....	12
<b>6. Ordering Information</b> .....	<b>13</b>
<b>7. Revision History</b> .....	<b>13</b>

## 1. Hardware Specifications

General Conditions (VIN= 3.6V and 25°C)

### 1.1. Recommended Operating Conditions

Rating	Min	Typical	Max	Unit
Operating Temperature Range	-40	-	85	°C
Supply Voltage V <sub>IN</sub>	2.3	3.6	4.8	Volts
Signal Pin Voltage	-	1.8	-	Volts
RF Frequency	2400	-	2483.5	MHz

### 1.2. Absolute Maximum Ratings

Rating	Min	Typical	Max	Unit
Storage temperature range	-55	-	+150	°C
Supply voltage V <sub>IN</sub>	-0.3	-	+5.0	Volts
I/O pin voltage V <sub>IO</sub>	-0.3	-	+2.5	Volts
RF input power	-	-	-5	dBm

### 1.3. Current Consumption

Modes (WLAN Max Power Consumption) V <sub>BAT</sub> =3.6v	Avg	Unit
Complete Power Down (PMUEN low)	17	μA
Sleep	101	μA
Power save (beacon period including DTIM 100ms, beacon length 1ms) -proprietary power saving features enabled	0.77	mA
RX (idle, 2.4GHz)	64.07	mA
RX (active, 2.4GHz, OFDM)	67.87	mA
TX (active, 2.4GHz, OFDM), 15.5dBm @RF port	242.67	mA
TX (active, 2.4GHz, OFDM), 20.5dBm @RF port	338.67	mA
TX (active, 2.4GHz, OFDM), 19.0dBm @RF port	285.67	mA
A VoIP call using a standard codec G.711 (64Kb/s, 320 byte packets) and U-APSD (WMM power save) power-saving mode.	4.65	mA
Video streaming; the device is receiving 2.0 Mbps of data using legacy PSM mode (for example, MPEG-4@2Mbps)	13.31	mA
I <sub>peak</sub> : system maximum peak current draw	378	mA

Modes (Bluetooth Typical Power Consumption)	Avg	Unit
System reset mode	6	μA
System deep sleep mode	30	μA
Page and inquiry scan (Page period=1.28s, Inquiry period=2.56S)	574	μA
Sniff in Master mode (Master, Tsniff=1.28s, 4 attempts, 0 sniff timeout)	129	μA
Sniff in Slave mode (Slave, Tsniff=1.28s, 4 attempts, 0 sniff timeout)	155	μA
Sniff in Master mode (Master, Tsniff=500ms, 4 attempts, 0 sniff timeout)	255	μA
Sniff in Slave mode (Slave, Tsniff=500ms, 4 attempts, 0 sniff timeout)	437	μA
HVS+Sniff in Master mode (HVS, Sniff (Master, 500ms, 4 attempts, 0 sniff timeout), P=1.28s; I=2.56s)	TBD	mA
HVS+Sniff in Slave mode (HV3, Sniff (Slave, 500ms, 4 attempts, 0 sniff timeout), P=1.28s; I=2.56s)	15.236	mA
2-EV3+Sniff in Master mode (2-EV3, T_eSCO=12, W_eSCO=2; Sniff (Master, 500ms, 4 attempts, 0 sniff timeout), P=1.28S; I=2.56s)	TBD	mA
2-EV3+Sniff in Slave mode (2-EV3, T_eSCO=12, W_eSCO=2; Sniff	9.728	mA

(Slave, 500ms, 4 attempts, 0 sniff timeout), P=1.28S; I=2.56s		
DH1 TX- DH5 RX in Master mode (@maximum throughput)	36.641	mA
DH1 TX- 3-DH5 RX in Master mode (@maximum throughput)	41.7	mA
DH5 TX- Null RX in Master mode (@maximum throughput)	TBD	mA
3-DH5 TX- Null RX in Master mode (@maximum throughput)	TBD	mA
A2DP from FM RX (TX 3-DH5- RX null, 400 kbps, A2DP SBC high quality joint stereo host off-load from FM RX48 kHz)	TBD	mA
A2DP from PCM/I2S1 and I2S2 (TX 3-DH5 - RX Null, 400 kbps,A2DP SBC high quality joint stereo host off-load from I2S 500 kHz burst mode)	TBD	mA
BLE: Advertising (nonconnectable) (Interval: 1.28s;Data:15; bytes 3 channels)	TBD	μA
BLE: Advertising (discoverable) (Interval: 1.28 s;Data: 15 bytes;3 channels)	TBD	μA
BLE: Scanning (Interval: 1.28 s;Window: 11.25 ms;Single frequency per window)	TBD	μA
Link layer connection (Master;Interval: 500 ms;Slave Latency: 0;Empty TX/RX packets)	TBD	μA
Link layer connection (Master;Interval: 1 s;Slave latency: 0;Empty TX packets;RX payload: 27 bytes)	TBD	μA

#### 1.4. Selected RF Characteristics

Parameters	Conditions	Typical	Unit
Antenna load		50	ohm
<b>Wi-Fi Receiver</b>			
Sensitivity	DSSS 1Mbps@FER<8%	-98	dBm
Sensitivity	DSSS 2Mbps@FER<8%	-95	dBm
Sensitivity	CCK 5.5Mbps@FER<8%	-93	dBm
Sensitivity	CCK 11Mbps@FER<8%	-91	dBm
Sensitivity	BPSK 6Mbps@PER<10%	-93.5	dBm
Sensitivity	BPSK 9Mbps@PER<10%	-91.5	dBm
Sensitivity	QPSK 12Mbps@PER<10%	-90.5	dBm
Sensitivity	QPSK 18Mbps@PER<10%	-88	dBm
Sensitivity	16QAM 24Mbps@PER<10%	-85	dBm
Sensitivity	16QAM 36Mbps@PER<10%	-82	dBm
Sensitivity	64QAM 48Mbps@PER<10%	-78	dBm
Sensitivity	64QAM 54Mbps@PER<10%	-76.5	dBm
Sensitivity	BPSK 6.5Mbps@PER<10%	-92	dBm
Sensitivity	QPSK 13Mbps@PER<10%	-89	dBm
Sensitivity	QPSK 19.5Mbps@PER<10%	-86.5	dBm
Sensitivity	16QAM 26Mbps@PER<10%	-84	dBm
Sensitivity	16 QAM 39Mbps@PER<10%	-80.5	dBm
Sensitivity	64QAM 52Mbps@PER<10%	-76.5	dBm
Sensitivity	64QAM 58.5Mbps@PER<10%	-74.5	dBm
Sensitivity	64QAM 65Mbps@PER<10%	-73	dBm
<b>Wi-Fi Receiver 5GHz 11n</b>			
Sensitivity	BPSK 6.5Mbps@PER<10%,Nss=1	-91	dBm
Sensitivity	QPSK 13Mbps@PER<10%, Nss=1	-88	dBm
Sensitivity	16QAM 26MbpsPER<10%,Nss=1	-83	dBm
Sensitivity	64QAM 65MbpsPER<10%,Nss=1	-72.5	dBm
<b>Wi-Fi Transmitter</b>			
Output Power	802.11b/g DSSS/CCK	21.25	dBm
Output Power	802.11b/g BPSK 1/2	21.25	dBm
Output Power	802.11b/g BPSK 3/4	21.25	dBm
Output Power	802.11b/g QPSK 1/2	21.25	dBm
Output Power	802.11b/g QPSK 3/4	21.25	dBm
Output Power	802.11b/g 16QAM 1/2	21.25	dBm
Output Power	802.11b/g 16QAM 3/4	20.25	dBm
Output Power	802.11b/g 64QAM 2/3	19.25	dBm
Output Power	802.11b/g 64QAM 3/4	18.25	dBm
Output Power	802.11n MCS-0	21.25	dBm
Output Power	802.11n MCS-1	21.25	dBm
Output Power	802.11n MCS-2	21.25	dBm
Output Power	802.11n MCS-3	21.25	dBm
Output Power	802.11n MCS-4	20.25	dBm
Output Power	802.11n MCS-5	19.25	dBm
Output Power	802.11n MCS-6	18.25	dBm
Output Power	802.11n MCS-7	17.00	dBm
<b>Wi-Fi Transmitter 5GHz, 11n</b>			
Output Power	802.11n MCS-0	19.5	dBm

Output Power	802.11n MCS-7	14.5	dBm
<b>Bluetooth Receiver</b>			
Receiver sensitivity (clean transmitter)	FSK (1Mbps), BER≤0.1%	-92	dBm
Receiver sensitivity (dirty transmitter)	FSK (1Mbps), BER≤0.1%	-91	dBm
EDR sensitivity 2 Mbps (clean transmitter)	PSK(2Mbps and 3Mbps), BER≤0.01%	-92	dBm
EDR sensitivity 3 Mbps (clean transmitter)	PSK(2Mbps and 3Mbps), BER≤0.01%	-86	dBm
EDR sensitivity 2 Mbps (dirty transmitter)	PSK(2Mbps and 3Mbps), BER≤0.1%	-91	dBm
EDR sensitivity 3 Mbps (dirty transmitter)	PSK(2Mbps and 3Mbps), BER≤0.1%	-85	dBm
<b>Bluetooth Transmitter</b>			
Frequency range		2400~2483.5	MHz
Maximum output power	FSK(1Mbps)	13	dBm
Minimum output power	FSK(1Mbps)	-20	dBm
Minimum output power in inquiry mode	FSK(1Mbps)	-30	dBm
Output power accuracy	FSK(1Mbps)	±2	dB
Maximum output power	PSK(2 Mbps)	10	dBm
Maximum output power	PSK(3 Mbps)	10	dBm
EDR relative transmit power	PSK(2Mbps and 3Mbps)	0	dB
Minimum output power	PSK(2Mbps and 3Mbps)	-20	dBm
<b>BLE Transmitter</b>			
Maximum output power		13	dBm
Minimum output power		-20	dBm
Minimum output power in advertising mode		-30	dBm
Output power accuracy		±2	dB
<b>BLE Receiver</b>			
Receiver sensitivity (clean transmitter)	PER<30.8%	-93	dBm
Receiver sensitivity (dirty transmitter)	PER<30.8%	-92	dBm

### 1.5. Pin Assignment WB61S

Name	Type	Pin #	Description	ALT Function
<b>Power and Ground</b>				
VIN		24	VIN	
GND		23	GND	
<b>Control</b>				
BTRST	I	21	BT Reset input	
WIFIRST	I	20	WLAN Reset input	
PMUEN	I	19	External PMU enable	
HOSTWK	O	5	Host Wakeup output	
GND		6	GND	
<b>UART</b>				
RXD	I	25	Receive data	
TXD	O	27	Transmit data	
RTS	O	26	Request to send (active low)	
CTS	I	22	Clear to send (active low)	
<b>SDIO</b>				
SDIO [0]	I/O	13	SDIO CMD	SPI DI
SDIO [1]	I/O	17	SDIO DATA0	SPI DO
SDIO [2]	I/O	18	SDIO DATA1	SPI INT
SDIO [3]	I/O	15	SDIO DATA3	SPI CSN
SDIO [4]	I/O	14	SDIO CLK	SPI CLK
SDIO [5]	I/O	16	SDIO DATA2	
SDIO INT	O	28	SDIO external interrupt	
<b>PCM</b>				
PCM	I/O	4	PCM SYNC	
PCM	I/O	2	PCM CLK	
PCM	I	3	PCM IN	
PCM	O	1	PCM OUT	
<b>External Antenna</b>				
GND		7	GND	
GND		8	GND	
GND		9	GND	
GND		10	GND	
ANT	I/O	11	Antenna port for WLAN and BT 2.4GHz	
ANT	I/O	29	Antenna port for WLAN 5GHz	
GND		12	GND	



### 1.6. Layout Drawing WB61S

Size: 26.9 mm x 15.2 mm x 2.8 mm (height)

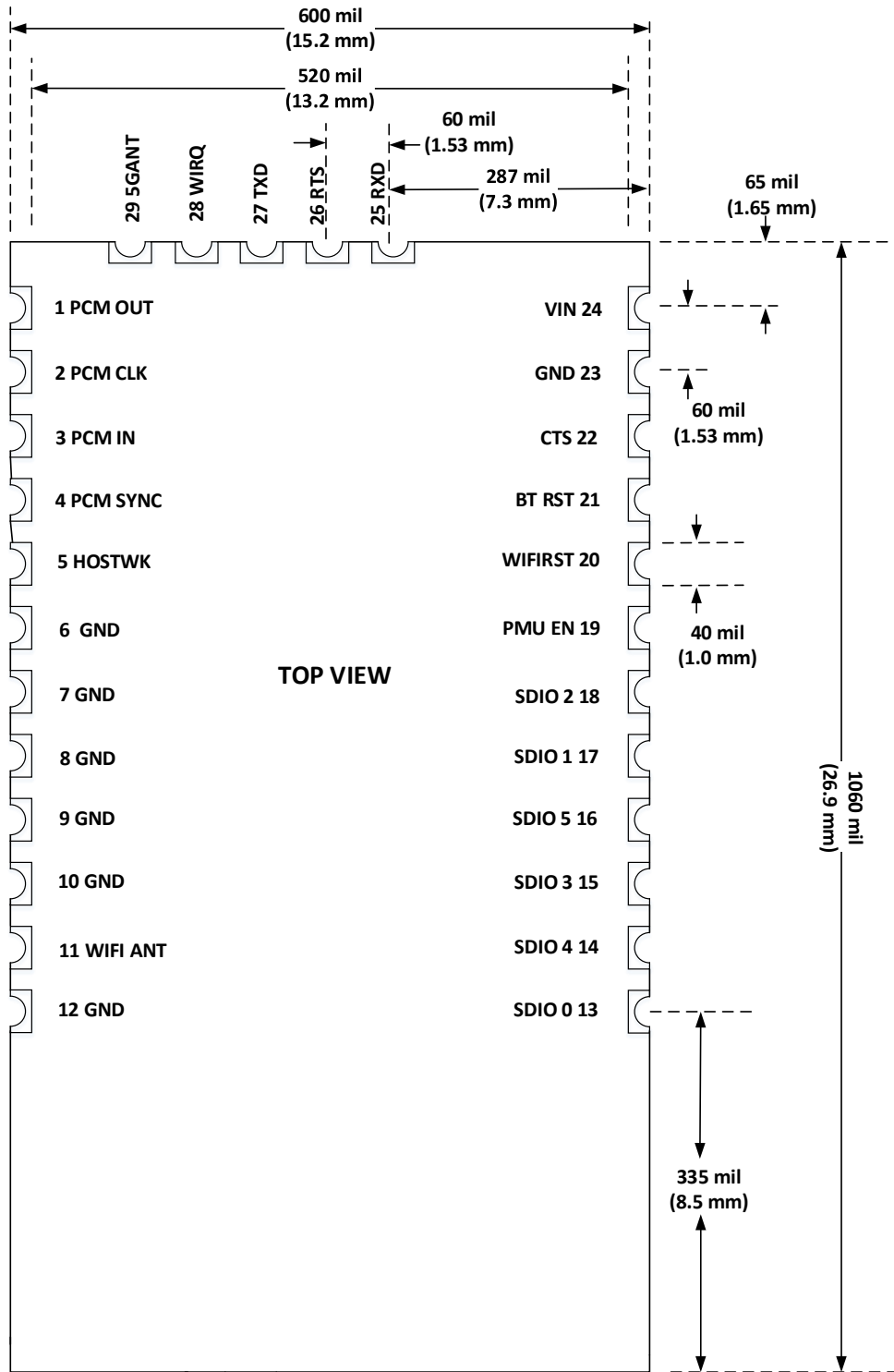

## 2. Hardware Design

- All unused pins should be left floating; do not ground.
- All GND pins must be well grounded.

- The area around the antenna should be free of any ground planes, power planes, trace routings, or metal for at least 6.5 mm in all directions.
- Traces should not be routed underneath the module.

## 2.1. Module Reflow Installation

The WB61 is a surface mount Bluetooth module supplied on a 29 pin, 6-layer PCB. The final assembly recommended reflow profiles are:

For RoHS/Pb-free applications, Sn96.5/Ag3.0/Cu0.5 solder is recommended.

- Maximum peak temperature of 230° - 240°C (below 250°C).
- Maximum rise and fall slope after liquidous of < 2°C/second.
- Maximum rise and fall slope after liquidous of < 3°C/second.
- Maximum time at liquidous of 40 – 80 seconds.

### 3. Reference Design Example WB61

The follow circuits are examples of typical Linux based platform connections to the WB51 module.

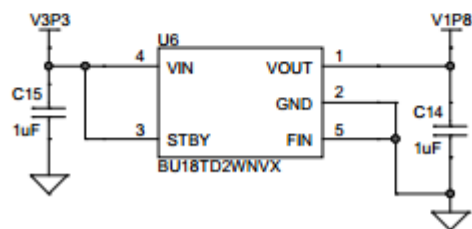
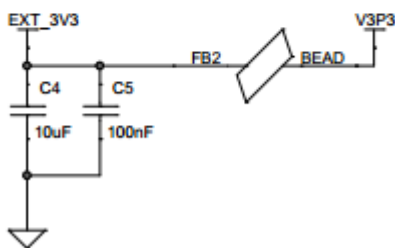
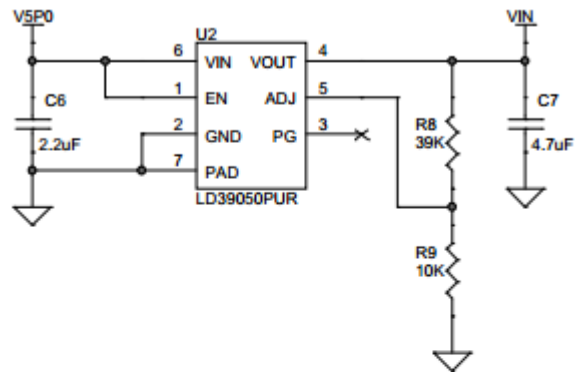
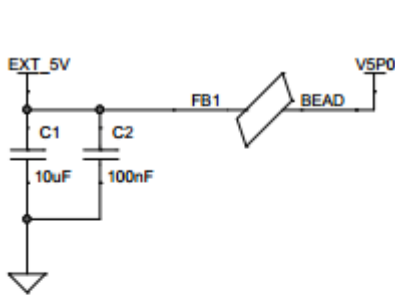
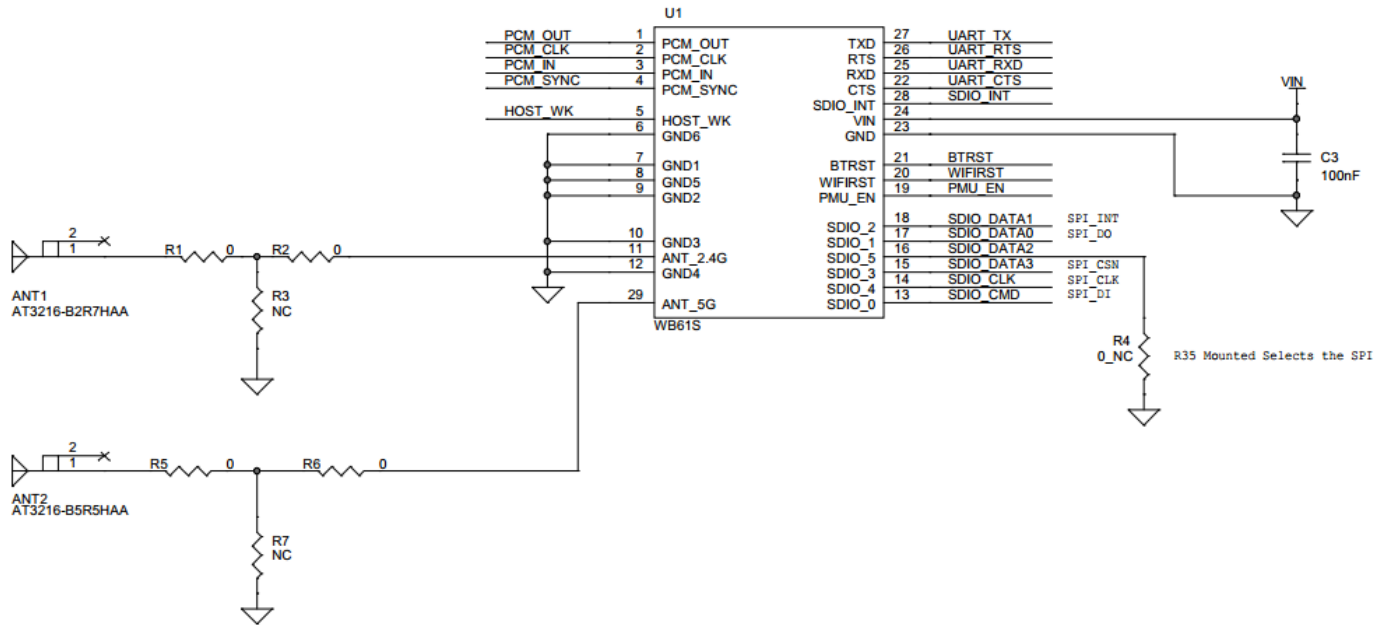

FXMA108BQX is Optional

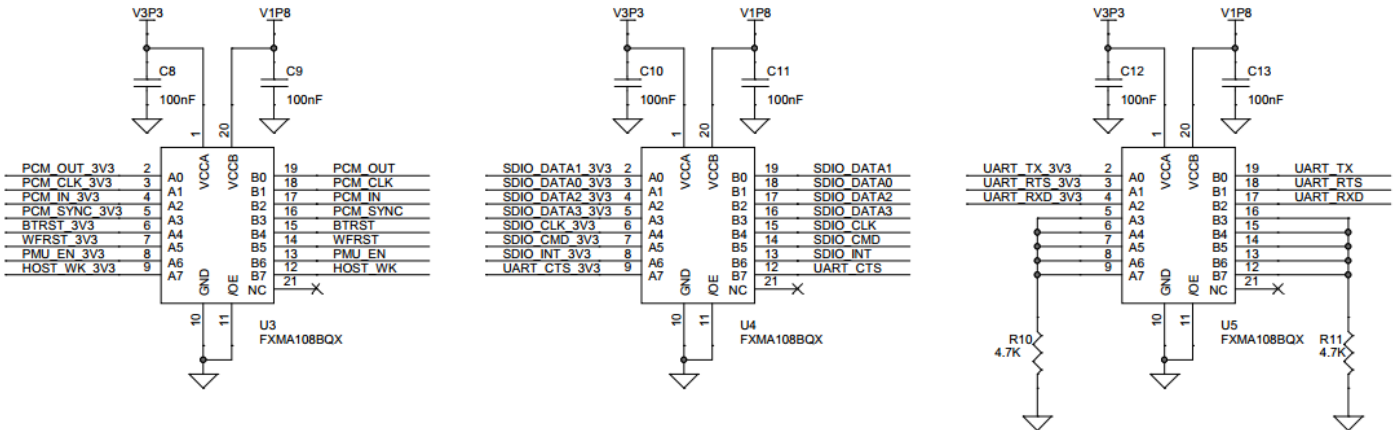

## 4. Startup behavior

### 4.1. RESET

This pin is always an input pin, active low, with a PD during reset. This signal MUST be active during power supplies initialization and, when all power supplies are stable, it must remain active low for at least 2 cycles of the slow clock in order to insure good reset functionality.

### 4.2. UART

UART\_CTS is an input with PU. UART\_RXD is an input with PU. UART\_TXD toggles from input PU to output High and UART\_RTS toggles from input PU to output Low 70ms after reset, enabling UART communication if needed.

### 4.3. SDIO and SPI interface

The SDIO interface is a four-wire to six-wire data interface (SDIO\_CLK, SDIO\_CMD, SDIO\_DATA0, SDIO\_DATA1/INT, optional SDIO\_DATA2 and SDIO\_DATA3). The physical SPI interface is a five-wire data interface: SPI\_CSN, SPI\_CLK, SPI\_DO, SPI\_DI, and SPI\_INT.

SDIO 5 is the selection pin. The state of this pin is monitored on the rising edge of WFRST.

- LOW selects SPI
- HIGH selects SDIO

## 5. RF Path Control

### 5.1. WB61S Control

Version	Path
WB61S	WLAN 2.4GHz uses internal ANT; BT uses internal ANT; WLAN 5GHz uses external antenna
WB61S-EXT	WLAN 2.4GHz uses external ANT; BT uses external ANT; WLAN 5GHz uses external antenna

## 6. Ordering Information

Part Name	Description
WB61S	Internal antenna for WLAN/BT 2.4GHz
WB61S-EXT	WB61 with external antennas only

## 7. Revision History

Date	Revision	Description
9 February 2016	1.0	First release
3 December 2016	1.1	Add reference design Add a sub-section for SDIO and SPI interface