

## **BT43 Datasheet**

Amp'ed RF Technology, Inc.

## BT43 Product Specification



11.6mm x 13.5mm

### Description

Our micro-sized Bluetooth module, with integrated antenna, is the smallest form factor available providing a complete RF platform. The BT43 supports both Bluetooth Classic and Low Energy, version v4.0.

The BT43 is a surface mount PCB module that provides fully embedded, ready to use Bluetooth wireless technology. Our standard abSerial and Amp'edUP Stack are pre-flashed into the integrated flash memory, supporting the SPP profile. Other standard Bluetooth profiles are also available.

Customized firmware for peripheral device interaction, power optimization, security, and other proprietary features may be supported and can be ordered pre-loaded and configured.

## BT43 Features

### Bluetooth features

- FCC & Bluetooth licensed radio
- Bluetooth v4.1
- Class 1 radio
- Range up to 80m LOS
- 1.5Mbps data throughput
- 128-bit encryption security

### Hardware configuration

- Cortex-M4 microprocessor up to 84MHz
- 256K bytes Flash memory
- 64K bytes RAM memory
- UART, up to 2M baud
- SPI and I2C interfaces
- 7 general purpose I/O
- 4x12-bit A/D inputs
- 1 LPO input

### Embedded software

- Amp'edUP dual mode Bluetooth stack: BT Classic and BT Low Energy
- abSerial, AT command set
- SDK, Software Development Kit (Optional)
- BlueGuard, data encryption software (Optional)
- Mobile application software (Optional)

### Additional documentation

- abSerial User Guide
- abSerial Reference Guide
- abSerial Configuration Guide

## Table of Contents

1	Software Architecture.....	4
1.1	Lower Layer Stack .....	4
1.2	Upper Layer Stack: Amp'ed UP .....	4
1.3	HCI Interface .....	4
1.4	AT Command Set: abSerial .....	4
2	Hardware Specifications .....	5
2.1	Recommended Operating Conditions.....	5
2.2	Absolute Maximum Ratings .....	5
2.3	Current Consumption .....	5
2.4	Selected RF Characteristics .....	6
2.5	I/O Operating Characteristics.....	6
2.6	Pin Assignment .....	7
2.7	Pin Placement Diagram (Top View).....	8
2.8	Layout Drawing .....	8
3	Module Block Diagram.....	9
4	Hardware Design .....	9
4.1	Module Reflow Installation .....	9
4.2	GPIO Interface .....	10
4.3	UART Interface .....	10
4.4	PCB Layout Guidelines .....	11
4.5	Reset Circuit.....	11
4.6	External LPO Input Circuit .....	12
4.7	Audio Application Reference Design .....	13
Part 1.	Module.....	13
Part 2.	Codec.....	14
Part 3.	Battery charging.....	14
Part 4.	Power control .....	15
Part 5.	LED indicator.....	15
5	Regulatory Compliance.....	15
5.1	Modular Approval, FCC and IC.....	17
5.2	FCC Label Instructions.....	17
5.3	CE .....	17
5.4	Bluetooth Qualification .....	17
6	Ordering Information .....	17
7	Feature Comparison .....	18
8	Revision History.....	18

# 1 Software Architecture

## 1.1 Lower Layer Stack

- Bluetooth v4.1, Classic and Low Energy
- Device power modes: active, sleep and deep sleep
- Wake on Bluetooth feature optimized power consumption of host CPU
- Authentication and encryption
- Encryption key length from 8 to 128 bits
- Persistent FLASH memory for BD Address and user parameter storage
- All ACL packet types.
- Bluetooth test modes per Bluetooth specification
- 802.11b/g/n co-existence: AFH
- Vendor specific HCI commands to support device configuration and certification test modes

## 1.2 Upper Layer Stack: Amp'ed UP

- SPP, GAP, ATT, GATT
- RFCOMM, SDP, and L2CAP

## 1.3 HCI Interface

- Bluetooth v4.0 specification compliant
- HCI UART transport layer (H4)

## 1.4 AT Command Set: abSerial

- Please see *abSerial Reference Guide* for details

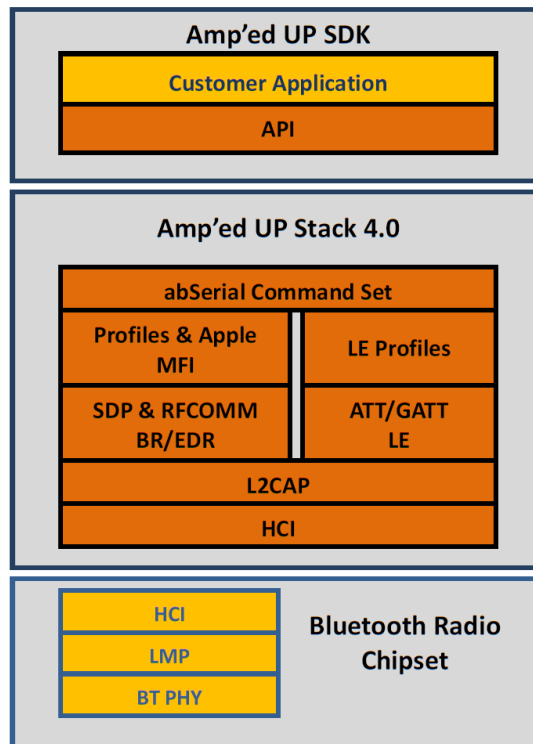

## 2 Hardware Specifications

General Conditions ( $V_{IN}= 2.5V$  and  $25^{\circ}C$ )

### 2.1 Recommended Operating Conditions

Rating	Min	Typical	Max	Unit
Operating Temperature Range	-40	-	85	$^{\circ}C$
Supply Voltage $V_{IN}$	2.0	2.5	3.6	Volts
Signal Pin Voltage	-	2.1	-	Volts
RF Frequency	2400	-	2483.5	MHz

### 2.2 Absolute Maximum Ratings

Rating	Min	Typical	Max	Unit
Storage temperature range	-55	-	+150	$^{\circ}C$
Supply voltage $V_{IN}$	-0.3	-	+5.0	Volts
I/O pin voltage $V_{IO}$	-0.3	-	+5.5	Volts
RF input power	-	-	-5	dBm

### 2.3 Current Consumption

Standard CPU Mode, 8 MHz <ul style="list-style-type: none"> <li>▪ UART supports up to 115 Kbps</li> <li>▪ Data throughput up to 200 Kbps</li> <li>▪ abSerial v1.5 (firmware)</li> <li>▪ Shallow Sleep enabled</li> </ul>		
Modes (Typical Power Consumption)	Avg	Unit
ACL data 115K Baud UART at max throughput (Master)	16.5	mA
ACL data 115K Baud UART at max throughput (Slave)	18.5	mA
Connection, no data traffic, master	5.2	mA
Connection, no data traffic, slave	7.4	mA
Connection, 375ms sniff, slave (external LPO required)	590	$\mu A$
Standby, without deep sleep	4.9	mA
Standby, with deep sleep, no external LPO	1.2	mA
Standby, with deep sleep, with external LPO	140	$\mu A$
Page/Inquiry Scan, with deep sleep, no external LPO	2.6	mA
Page/Inquiry Scan, with deep sleep, with external LPO	720	$\mu A$
BLE Advertising, 1.28s, non-connectable, with external LPO	195	$\mu A$
BLE Advertising, 1.28s, discoverable, with external LPO	215	$\mu A$
Bluetooth power down / CPU standby	11	$\mu A$

## 2.4 Selected RF Characteristics

Parameters	Conditions	Typical	Unit
Antenna load		50	ohm
<b>Radio Receiver</b>			
Sensitivity level	BER < .001 with DH5	-92	dBm
Maximum usable level	BER < .001 with DH1	0	dBm
Input VSWR		2.5:1	
<b>Radio Transmitter</b>			
Maximum output power	50 Ω load	+12	dBm
Initial Carrier Frequency Tolerance		0	kHz
20 dB Bandwidth for modulated carrier		935	kHz

## 2.5 I/O Operating Characteristics

Symbol	Parameter	Min	Max	Unit	Conditions
V <sub>IL</sub>	Low-Level Input Voltage	-	0.6	Volts	V <sub>IN</sub> , 2.1V
V <sub>IH</sub>	High-Level Input Voltage	1.4	-	Volts	V <sub>IN</sub> , 2.1V
V <sub>OL</sub>	Low-Level Output Voltage	-	0.4	Volts	V <sub>IN</sub> , 2.1V
V <sub>OH</sub>	High-Level Output Voltage	1.8	-	Volts	V <sub>IN</sub> , 2.1V
I <sub>OL</sub>	Low -Level Output Current	-	4.0	mA	V <sub>OL</sub> = 0.4 V
I <sub>OH</sub>	High-Level Output Current	-	4.0	mA	V <sub>OH</sub> = 1.8V
R <sub>PU</sub>	Pull-up Resistor	80	120	KΩ	Resistor Turned On
R <sub>PD</sub>	Pull-down Resistor	80	120	KΩ	Resistor Turned On

## 2.6 Pin Assignment

Name	Type	Pin #	Description	ALT Function	5V Tolerant	Initial State
<b>UART Interface</b>						
RXD	I	13	Receive data		Y	
TXD	O	14	Transmit data		Y	
RTS	O	12	Request to send (active low)	I2C Data	Y	
CTS	I	11	Clear to send (active low)	I2C Clock	Y	
<b>Reserved</b>						
BOOT 0	I	9	Reserved			
<b>Power and Ground</b>						
VIN		8	VIN			
GND		7	GND			
LDOOUT		18	LDO OUTPUT 2.1V (80mA)			
<b>Reset</b>						
RESETN	I	10	Reset input (active low for 5 ms)		2.5V max	
<b>LPO</b>						
LPO	I	15	Low power clock input (optional)			
<b>GPIO – General Purpose Input/Output</b>						
GPIO [1]	I/O	1	General Purpose Input/Output	SPI MISO	Y	Input pull down
GPIO [2]	I/O	2	General Purpose Input/Output	SPI MOSI/I2S_SD	Y	Floating
GPIO [3]	I/O	3	General Purpose Input/Output	SPI SCLK/ I2S_SCK	Y	Input pull down
GPIO [4]	I/O	4	General Purpose Input/Output	SPI SS/I2S_WS	Y	Input pull down
GPIO [5]	I/O	5	General Purpose Input/Output	I2C Data	Y	Input pull down
GPIO [6]	I/O	6	General Purpose Input/Output	I2C Clock	Y	Input pull down
GPIO [7]	I/O	17	General Purpose Input/Output	ADC 0	Y	Input pull down
GPIO [8]	I/O	16	General Purpose Input/Output (BT43H only)	ADC 1	Y	Input pull down

### 2.7 Pin Placement Diagram (Top View)

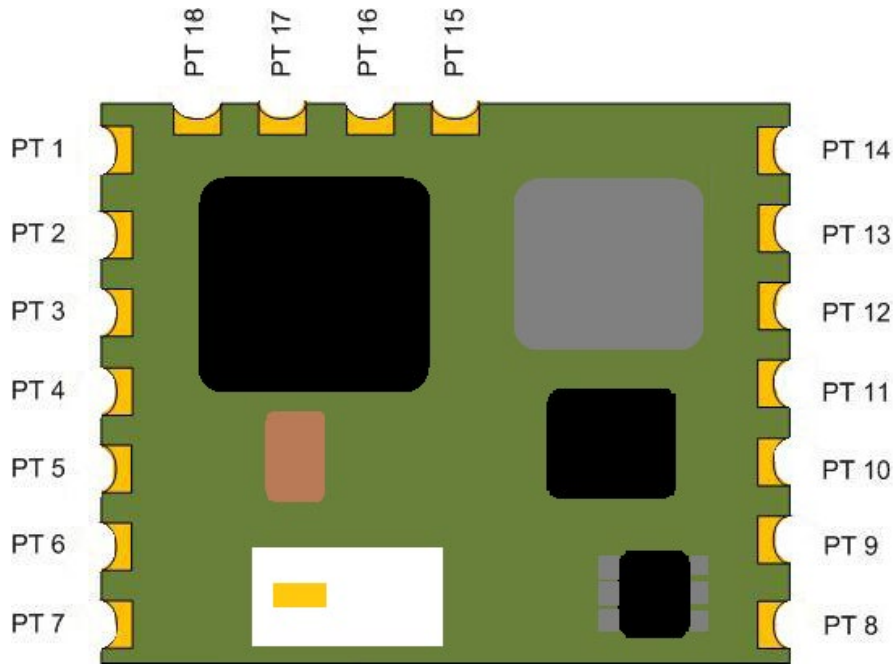

### 2.8 Layout Drawing

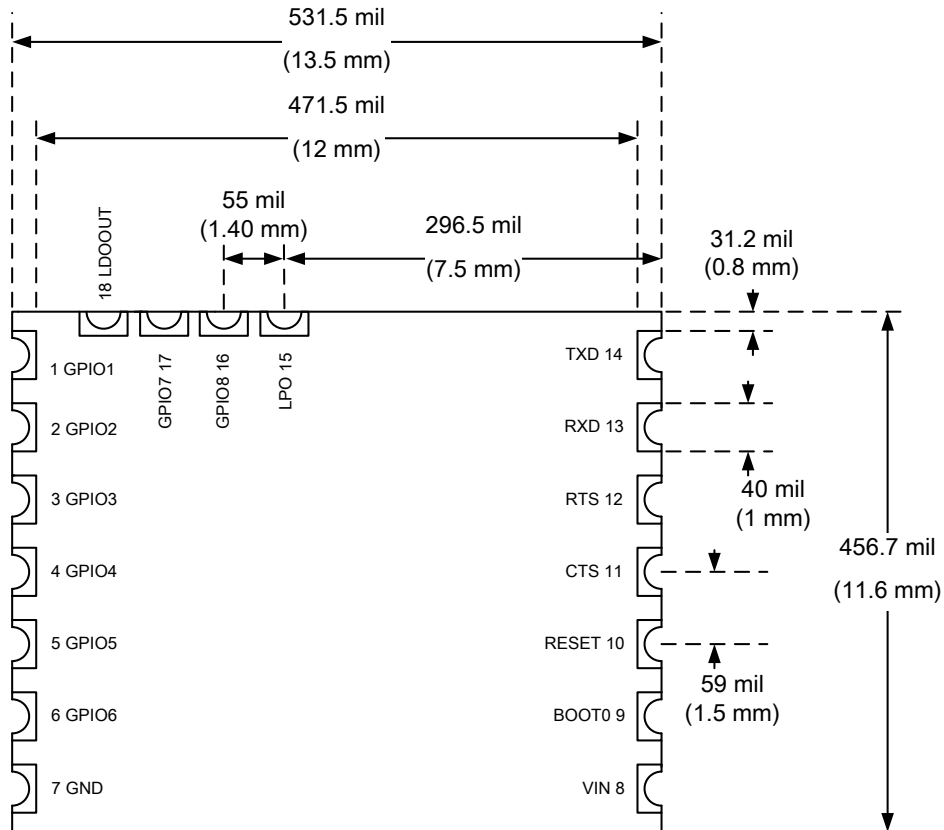

Height: 13.5 mm x 11.6 mm x 2.8 mm (tolerance +/-0.2mm)



### 3 Module Block Diagram

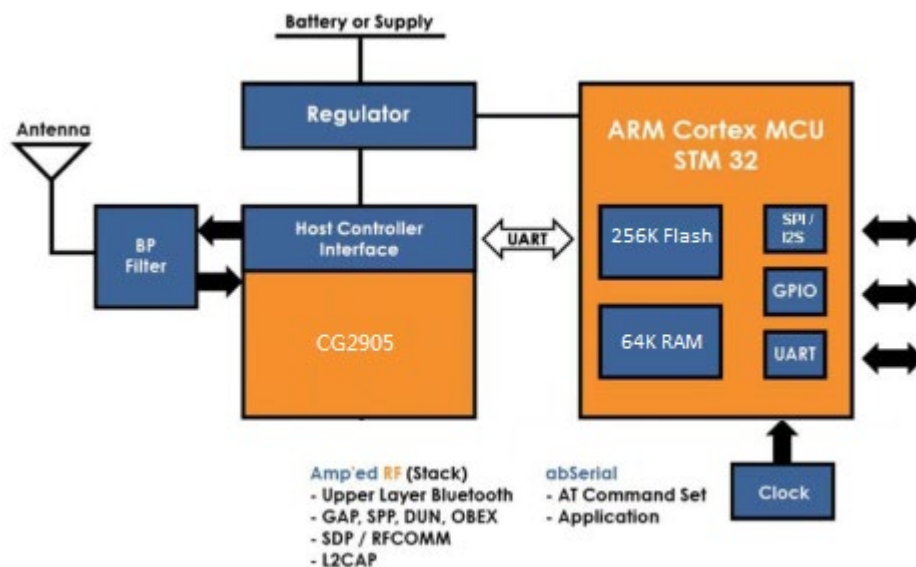

### 4 Hardware Design

Amp'ed RF modules support UART, USB, SPI, and GPIO hardware interfaces. Please note that the usage of these interfaces is dependent upon the firmware that is loaded into the module, and is beyond the scope of this document. The AT command interface uses the main UART by default.

#### Notes

- All unused pins should be left floating; do not ground.
- All GND pins must be well grounded.
- The area around the antenna should be free of any ground planes, power planes, trace routings, or metal for at least 6 mm in all directions.
- Traces should not be routed underneath the module.

#### 4.1 Module Reflow Installation

The BT43 is a surface mount Bluetooth module supplied on a 16 pin, 6-layer PCB. The final assembly recommended reflow profiles are:

For RoHS/Pb-free applications, Sn96.5/Ag3.0/Cu0.5 solder is recommended.

- Maximum peak temperature of 230° - 240°C (below 250°C).
- Maximum rise and fall slope after liquidous of < 2°C/second.
- Maximum rise and fall slope after liquidous of < 3°C/second.
- Maximum time at liquidous of 40 – 80 seconds.

## 4.2 GPIO Interface

All GPIOs are capable of sinking and sourcing 6mA of I/O current.

## 4.3 UART Interface

The UART is compatible with the 16550 industry standard. Four signals are provided with the UART interface. The TXD and RXD pins are used for data while the CTS and RTS pins are used for flow control.

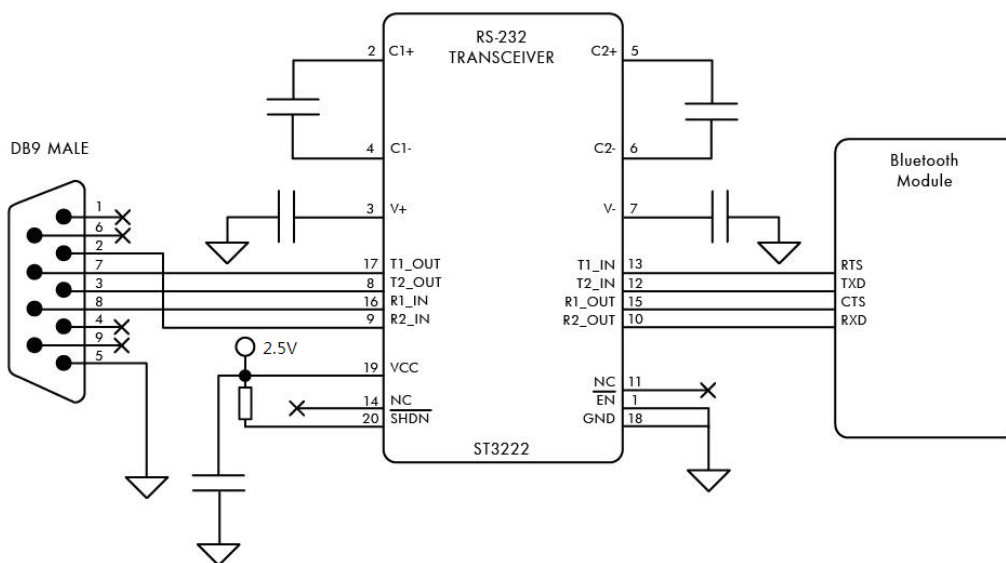
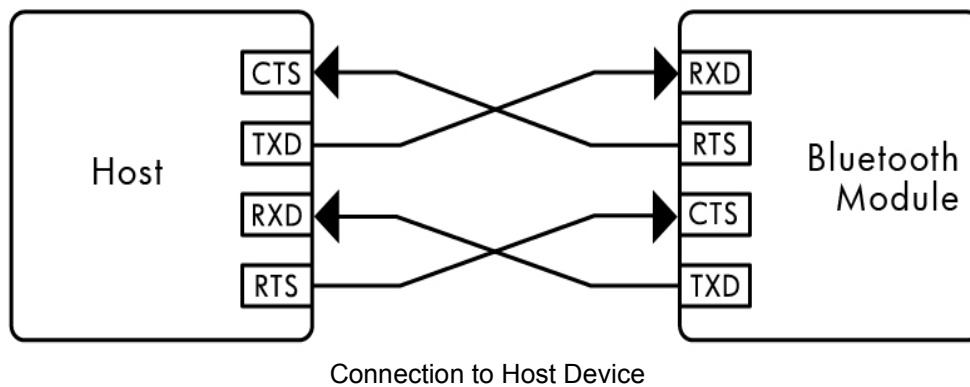

#### 4.4 PCB Layout Guidelines

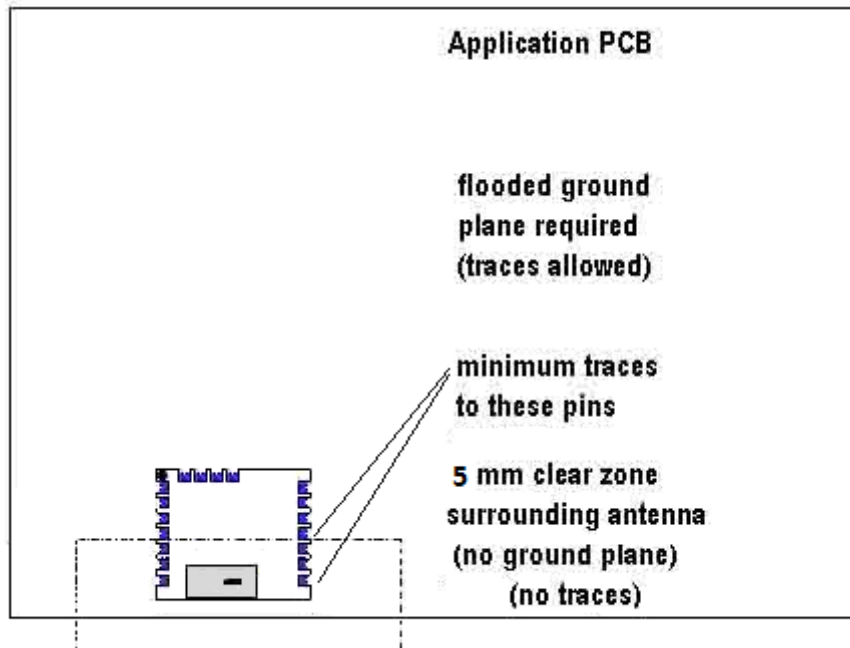

#### 4.5 Reset Circuit

Two types of system reset circuits are detailed below.

##### 4.5.1 External Reset Circuit:

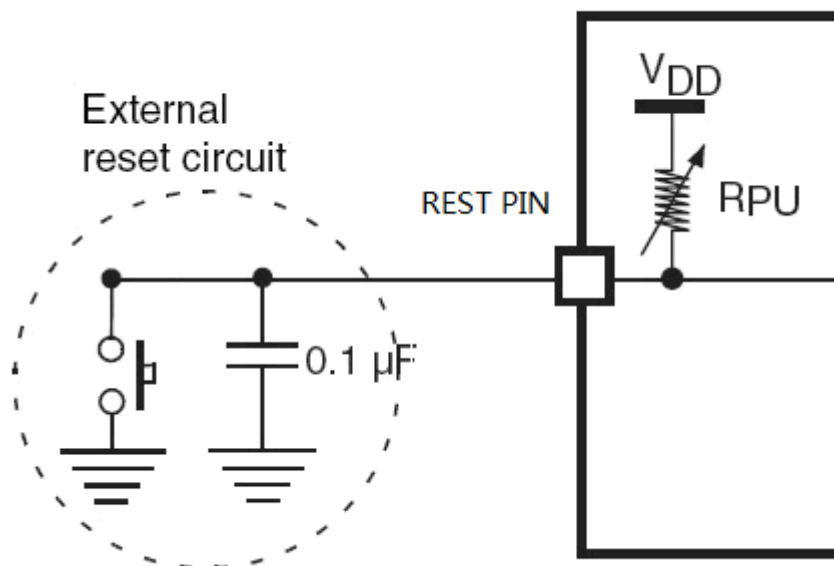

Note: R<sub>PU</sub> ranges from 30K ohm to 50K ohm internally.

#### 4.5.2 Internal Reset Circuit:

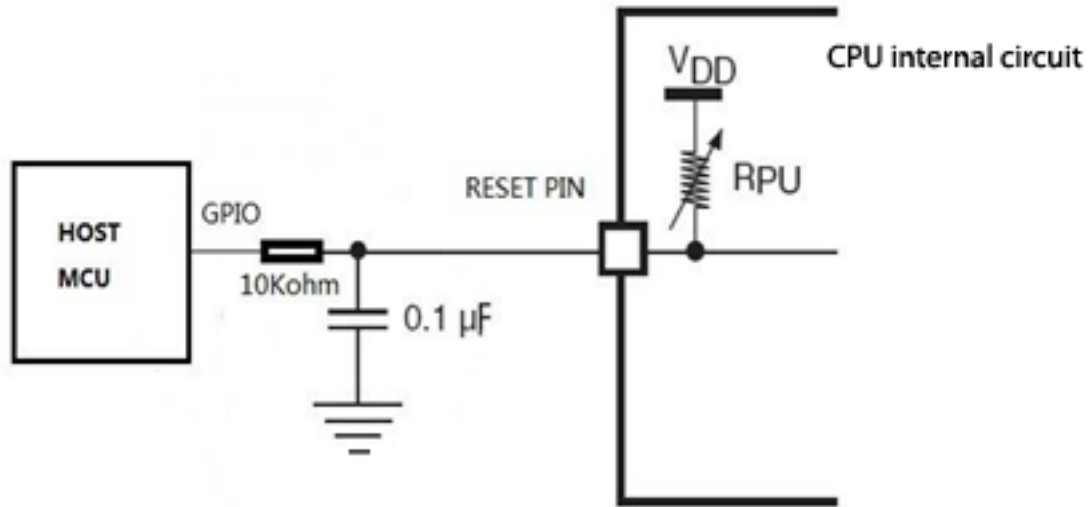

Notes:

- $R_{PU}$  ranges from 30K ohm to 50K ohm internally.
- $R_{RST}$  should be from 1K ohm to 10K ohm

#### 4.6 External LPO Input Circuit

An optional low power oscillator input may be added to allow deep sleep and sniff modes.

**Ext 32.768 KHz Clock Input (LPO)**

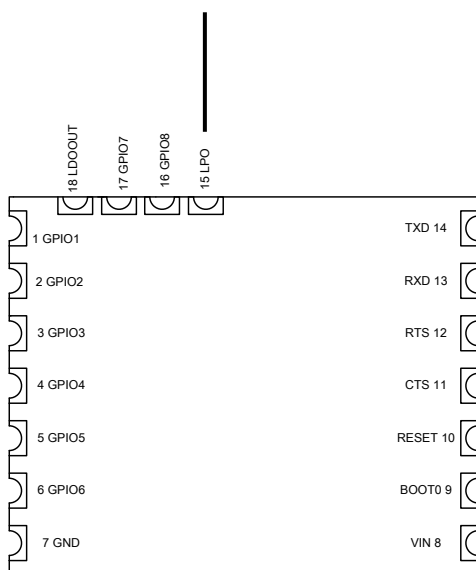

#### LPO Parameters:

Frequency: 32.768 KHz

Tolerance: 150 ppm

Voltage Levels:

Low: 0.1 V

High: 1.8 V

Input Capacitance: 2.5 pF maximum

#### Configurations:

See configuration guide:

UseExtLPO

AllowSniff

### 4.7 Audio Application Reference Design

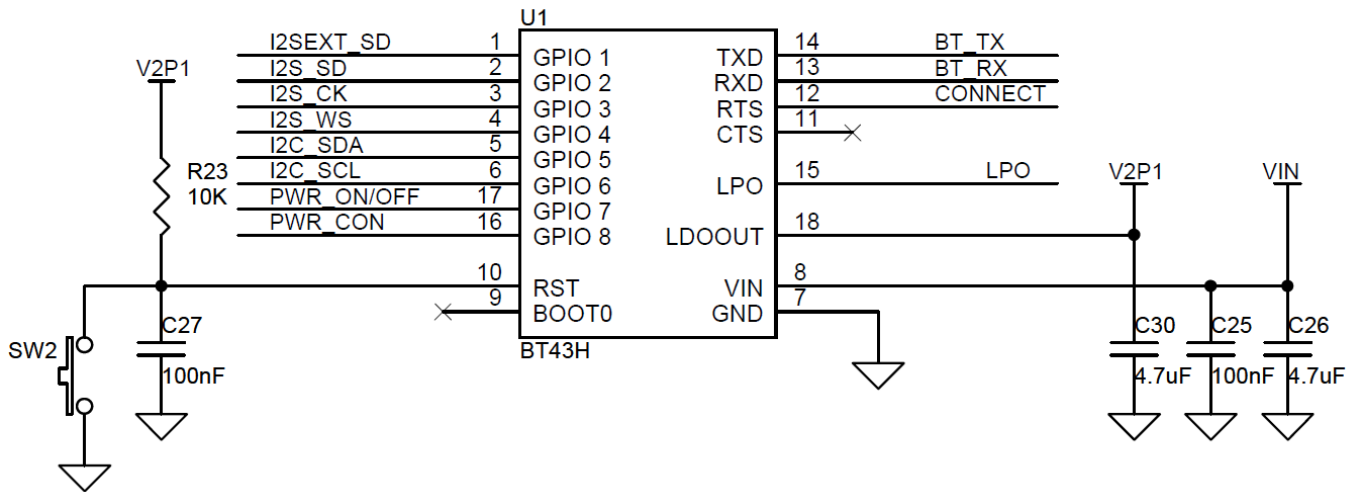

Part 1. Module

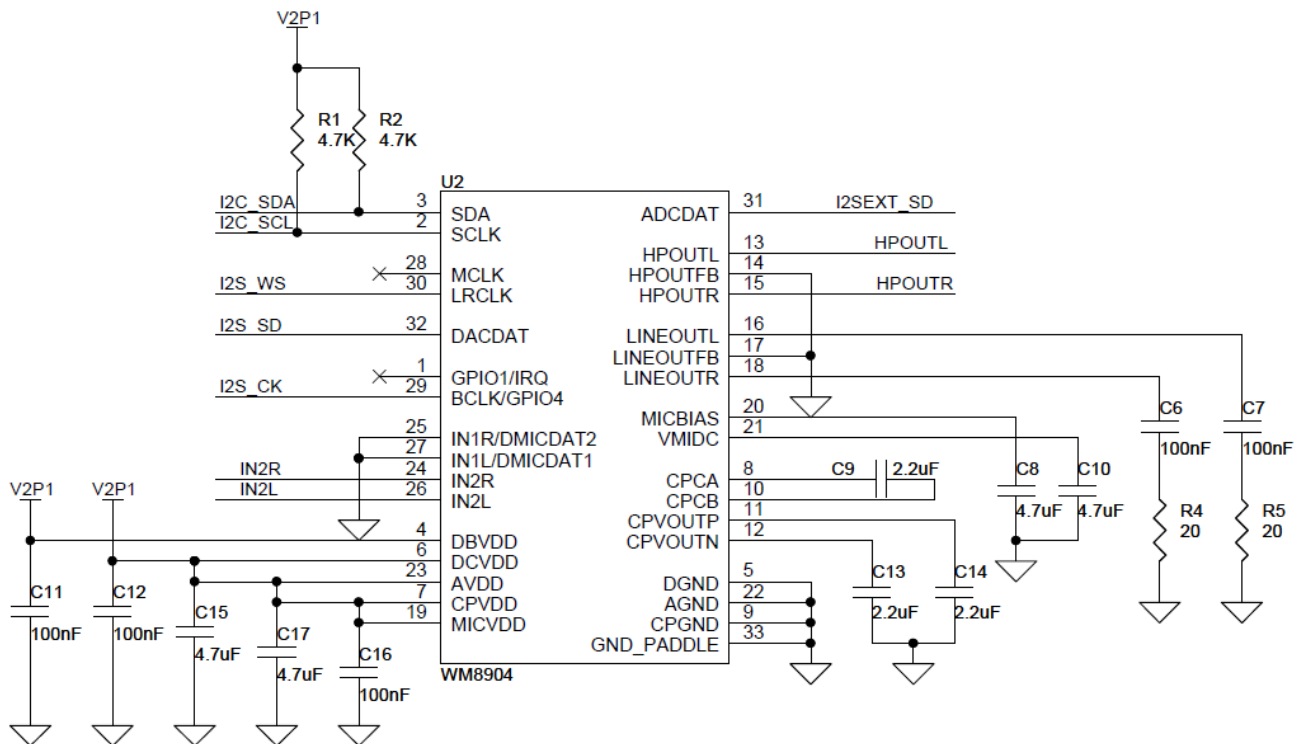

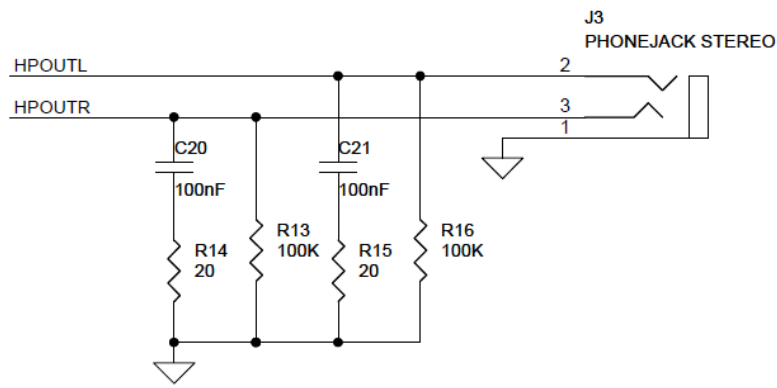
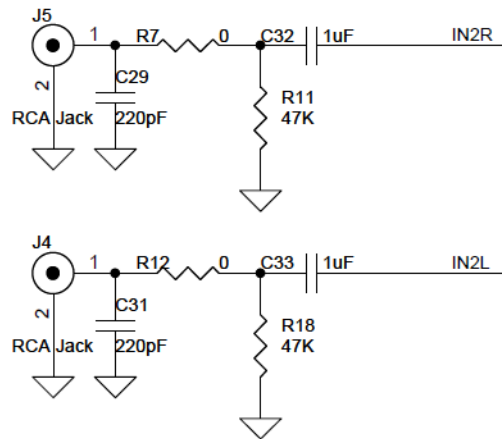

Part 2. Codec

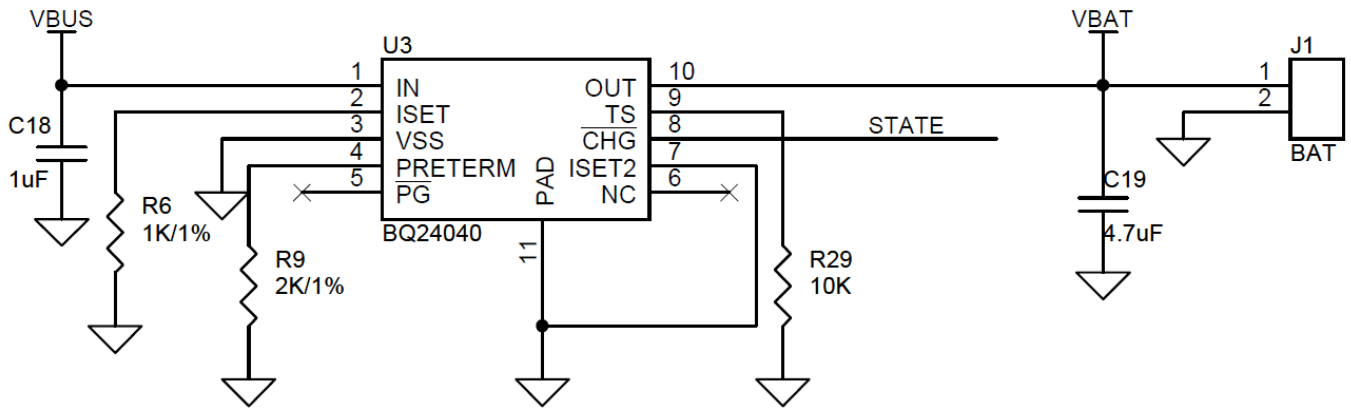

Part 3. Battery charging

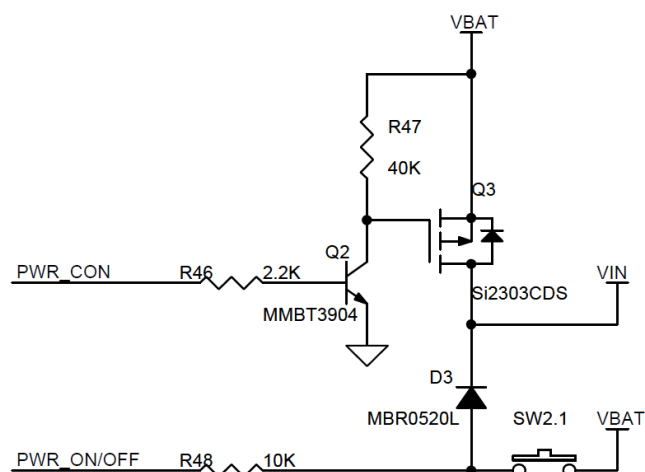

Part 4. Power control

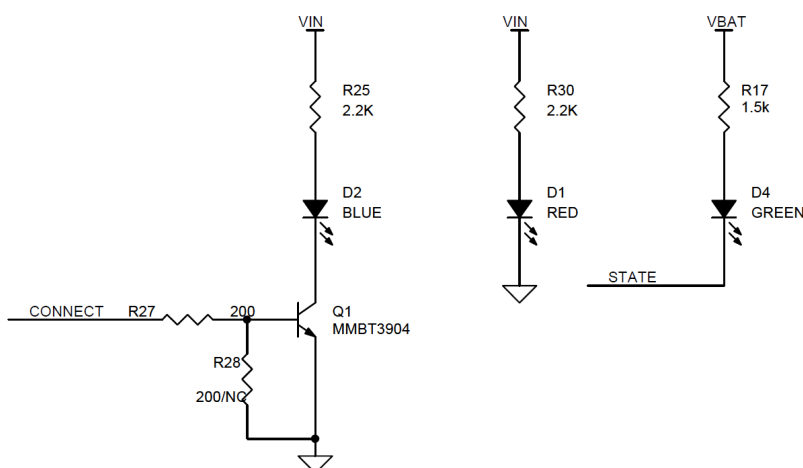

Part 5. LED indicator

## 5 Regulatory Compliance

### Federal Communications Commission statement:

This module has been tested and found to comply with the FCC Part15.

These limits are designed to provide reasonable protection against harmful interference in approved installations. This equipment generates, uses, and can radiate radio frequency energy and, if not installed and used in accordance the instructions, may cause harmful interference to radio communications. However, there is no guarantee that interference will not occur in a particular installation.

This device complies with part 15 of the FCC Rules. Operation is subject to the following two conditions: (1) This device may not cause harmful interference, and (2) this device must accept any interference received, including interference that may cause undesired operation.

Modifications or changes to this equipment not expressly approved by Amp'ed RF Technology may void the user's authority to operate this equipment.

The modular transmitter must be equipped with either a permanently affixed label or must be capable of electronically displaying its FCC identification number

(A) If using a permanently affixed label, the modular transmitter must be labeled with its own FCC identification number, and, if the FCC identification number is not visible when the module is installed inside another device, then the outside of the device into which the module is installed must also display a label referring to the enclosed module. This exterior label can use wording such as the following: “Contains Transmitter Module FCC ID: X3ZBTMOD8” or “Contains FCC ID: X3ZBTMOD8.”

(B) If the modular transmitter uses an electronic display of the FCC identification number, the information must be readily accessible and visible on the modular transmitter or on the device in which it is installed. If the module is installed inside another device, then the outside of the device into which the module is installed must display a label referring to the enclosed module. This exterior label can use wording such as the following: “Contains FCC certified transmitter module(s).”

To satisfy FCC RF Exposure requirements for mobile and base station transmission devices, a separation distance of 20 cm or more should be maintained between the antenna of this device and persons during operation. To ensure compliance, operation at closer than this distance is not recommended. The antenna(s) used for this transmitter must not be co-located or operating in conjunction with any other antenna or transmitter.

**Industry Canada statement:**

Label of the end product:

The final end product must be labeled in a visible area with the following "Contains transmitter module IC: 8828A-MOD8"

This Class B digital apparatus complies with Canadian ICES-003.

Cet appareil numérique de la classe B est conforme à la norme NMB-003 du Canada.

This device complies with RSS-210 of the Industry Canada Rules. Operation is subject to the following two conditions: (1) This device may not cause harmful interference, and (2) this device must accept any interference received, including interference that may cause undesired operation.

Ce dispositif est conforme à la norme CNR-210 d'Industrie Canada applicable aux appareils radio exempts de licence. Son fonctionnement est sujet aux deux conditions suivantes: (1) le dispositif ne doit pas produire de brouillage préjudiciable, et (2) ce dispositif doit accepter tout brouillage reçu, y compris un brouillage susceptible de provoquer un fonctionnement indésirable.



### 5.1 Modular Approval, FCC and IC

FCC ID: X3ZBTMOD7

IC: 8828A-MOD7

In accordance with FCC Part 15, the BT43 is listed above as a Modular Transmitter device.

### 5.2 FCC Label Instructions

The outside of final products that contain a BT43 device must display a label referring to the enclosed module. This exterior label can use wording such as the following:

Contains Transmitter Module

FCC ID: X3ZBTMOD7

IC: 8828A-MOD7

Any similar wording that expresses the same meaning may be used.

### 5.3 CE

Registration No.: AT 50284024 0001

Report No.: 15070161 001

### 5.4 Bluetooth Qualification

Declaration ID: D023197

## 6 Ordering Information

Part Name	Description
BT43H	High performance version
BT43S	Audio application version

## 7 Feature Comparison

Features	BT43H	BT43S
CPU Speed	84MHz Max.	84MHz Max.
CPU Memory	256K Flash, 64K RAM	256K Flash, 64K RAM
Bluetooth Profile Support	SPP, IAP, HID, OBEX	SPP, IAP, A2DP, HFP, AVRCP, HID, OBEX
Bluetooth Stack	Amp'edUP, BT v4.1 + BLE	Amp'edUP, BT v4.1 + BLE
Apple iOS Support	Supported	Supported
AT Command Interface	abSerial	abSerial
Multiple Connections	7 Max.	7 Max.
Link Throughput	1.5M bps max	1.5M bps max
Serial Interface	UART, I2S, I2C, SPI	UART, I2S, I2C, SPI
General I/O Lines	7	7
A/D Lines	4	4

## 8 Revision History

Date	Revision	Description
30 Oct 2012	1	First release
16 Jan 2013	1.1	Updated power consumption table
15 July 2013	1.2	Added versions BT43A and BT43LT
15 Feb 2014	1.3	Added BT43H version. Replacement for BT43A. Added FCC and IC ID information.
21 May 2014	1.4	Removed BT43LT information. Added the audio reference circuit.
20 June 2014	1.5	Update the picture of BT43H
29 Aug 2014	1.6	Added BT43S information
5 Mar 2015	1.7	Update the layout drawing, and the regulatory compliance.